



CONVEYX
SOLUTIONS, LLC

GRAVITY ROLLER CONVEYOR

INSTALLATION, OPERATION & MAINTENANCE MANUAL

PLEASE REVIEW MANUAL BEFORE OPERATING EQUIPMENT

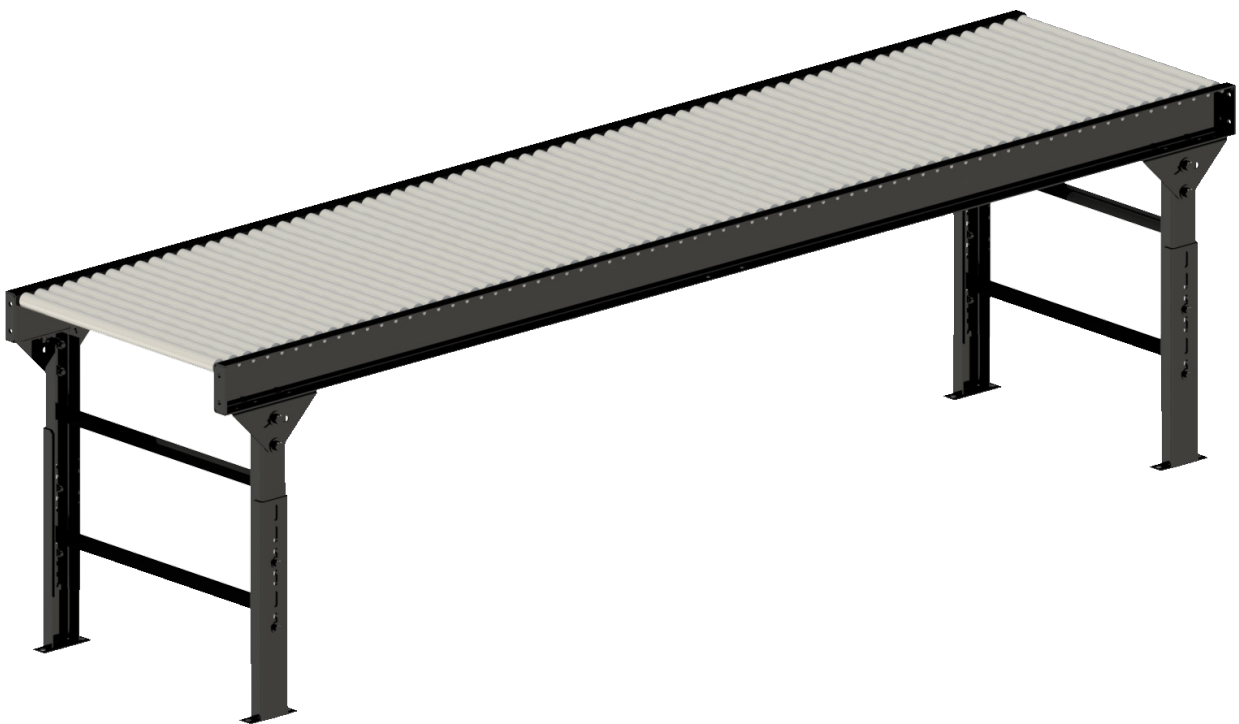
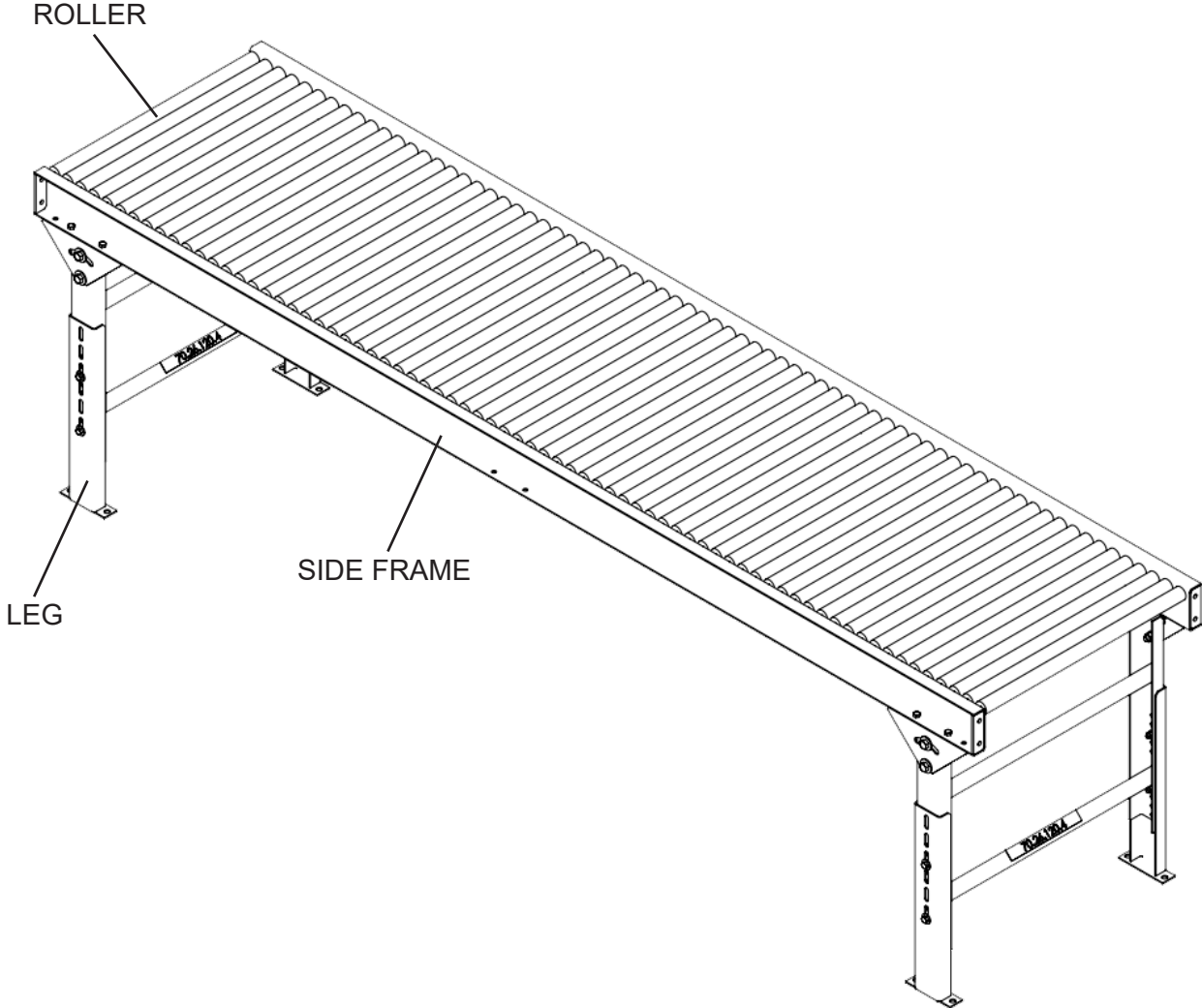

TABLE OF CONTENTS

- General Overview 3
- Warnings and Safety Instructions 4
- ANSI Conveyor Safety Rules..... 5
- CEMA Standards for Conveyors..... 5
- Pre-Installation Inspection 6
- Installation..... 7
 - Squaring 7
 - Coupling..... 7
 - Leg Installation and Adjustment..... 8
 - Knee Braces 10
 - Casters 11
 - Ceiling Hangers 11
 - Multi-Tier Supports 12
- General Preventative Maintenance 13
- Parts Replacement Procedures..... 14
- General Troubleshooting 15
- Warranty Statement..... 16
- Return Authorization Procedures..... 17
- Parts Reference Chart & Drawings..... 18

GENERAL OVERVIEW

The Gravity Conveyor is designed for automatic declined product transportation or easy manual movement of materials. The Gravity Conveyor is a non-powered conveyor that is comprised of rollers, side frames, and optional legs. For general conveyor terminology, see image below.



WARNINGS AND SAFETY INSTRUCTIONS

Failure to follow the instructions and cautions throughout this manual and warning labels on the conveyor, may result in injury to personnel or damage to the equipment.

Special attention must be paid to the following areas of this manual:



WARNING

Indicates a potentially hazardous situation which, if not avoided, could result in death or serious injury.

CAUTION

Indicates a situation which, if not avoided, could result in property damage.

NOTE

Indicates helpful hints and information.

ENVIRONMENTAL STANDARDS

ConveyX Solutions, LLC's equipment is designed to be installed in a clean, dry environment. Exposure to extreme humidity, direct sunlight, blowing dirt or rain can permanently damage some components and equipment. Concrete curing agents are also known to attack and degrade the urethane conveyor components. Be sure that the concrete is properly cured at new sites before setting the conveyor on it and that proper ventilation is used to prevent curing agent fumes from impacting the conveyor. Equipment should be stored under cover to protect it from exposure to the weather and other adverse conditions from the dock door to the truck entrance. Failure to comply with these guidelines will void the warranty on any failed components that result from these environmental issues.

ANSI STANDARDS FOR CONVEYORS

It is essential for safe and efficient system operation that the safety information and guidelines presented here are properly understood and implemented. The American National Standard Institute (ANSI) offers a booklet entitled Safety Standards for Conveyors and Related Equipment, for more information contact <https://webstore.ansi.org>.

With any piece of industrial equipment, conditions exist that might cause injury to workers. Because it is not possible to describe each potentially hazardous situation that might develop, workers must be alert at all times for unsafe conditions. To avoid injury, use maximum possible care and common sense and adhere to all safety standards.

Take special care while maintaining and inspecting electrical equipment and devices. All personnel working on or around the system should be aware of, and adhere to all CAUTION, DANGER and WARNING signs.

Labels or signs are posted to reduce the risk of injury to all personnel. Never assume that the signs and notices are applicable only to inexperienced personnel. Maintain signs in a legible condition. Contact a supervisor to post additional safety signs if necessary.

ANSI CONVEYOR SAFETY RULES

Below are the conveyor safety rules, as well as specific regulations and guidelines listed in this publication:

- DO NOT touch moving conveyor parts.
- DO NOT walk, ride or climb on the conveyor.
- DO NOT operate the conveyor with chain guards or other protective guards removed.
- Keep jewelry, clothing, hair, etc., away from the conveyor.
- Know the location and function of all START/STOP devices (if applicable) and keep those devices free from obstruction.
- Clear all personnel from the equipment before starting the conveyor.
- DO NOT attempt to clear product jams while the conveyor is running.
- Allow only trained and authorized personnel to maintain or repair conveyor equipment.
- DO NOT load the conveyor beyond specified design limits.
- DO NOT attempt to make repairs to the conveyor while it is running.
- DO NOT modify equipment without checking with the manufacturer.
- DO NOT operate or perform maintenance on equipment when taking any type of drug or sedative, when under the influence of alcohol or when over-fatigued.
- Report any unsafe condition to your supervisor or maintenance staff.

CEMA STANDARDS FOR CONVEYOR

The Conveyor Equipment Manufacturers Association (CEMA) provides safety information related to conveyor systems. To learn more about CEMA visit website, www.cemanet.org.

CEMA produces various Conveyor safety videos and posters, and it is recommended that the videos be made available for training and education purposes as part of a safe working environment around conveyor equipment. The videos introduce awareness of operations, personnel, maintenance technicians and safety hazard management commonly associated with the automated material-handling conveyor equipment.

The safety posters review important safety labels and are intended to be posted in public places as a day-to-day reinforcement of good safety practices. These posters can be downloaded from the CEMA website at: <https://cemanet.org/posters-videos>.

SAFETY INSTRUCTIONS



WARNING

- Do not exceed the conveyor load capacity, as it may result in possible operator injury or conveyor damage.
- Avoid wearing excessively loose clothing when working with moving equipment.
- Keep long hair pulled up to prevent it from becoming caught in moving parts.
- Broken or worn parts must be replaced immediately.
- Gravity Conveyors must only be serviced by properly trained and qualified technicians.

PRE-INSTALLATION INSPECTION



WARNING

Follow all proper safety precautions and plant installation procedures.

If you find any damage to the conveyor upon inspection or any loose wires, contact the factory BEFORE applying power to the conveyor.

INSPECTION

1. Prior to unpacking and de-stacking the Gravity Conveyor, perform a visual inspection for any mechanical components that may be improperly connected or attached to the shipping pallet or banding.
2. Unpack the Gravity Conveyor and inspect for any possible damage that may have occurred during shipping. If you find any physical damage to the conveyor upon inspection, contact the factory BEFORE assembling or installing the conveyor.
3. Inspect the rollers to ensure the rollers were not damaged during shipping. If the rollers are bent, the conveyor will not move products or operate properly resulting in poor performance. The conveyor rollers will need to be replaced. Contact the factory for parts and further instruction.
4. Inspect any casters and legs to ensure no damage has occurred during shipping. If any damage has occurred, then the conveyor will need to be repaired. Contact the factory for parts and further instruction.
5. Inspect each leg assembly for physical damage, loose and/or missing parts. Verify that the height is correct and that the adjustment fasteners are in place and secure. If the conveyor bed is not at the correct height, adjust the leg to the proper height and secure the fasteners.
6. Inspect all frame work to ensure that no damage occurred during shipping. If frames are damaged or bent, the conveyor will need repairs. Contact the factory for parts and further instructions.

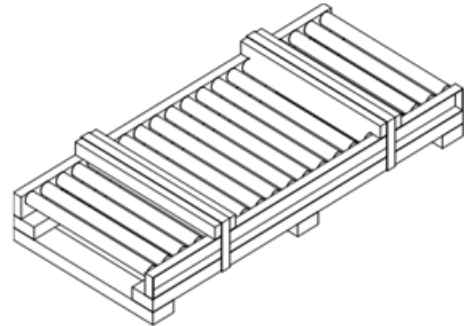

SINGLE SECTION

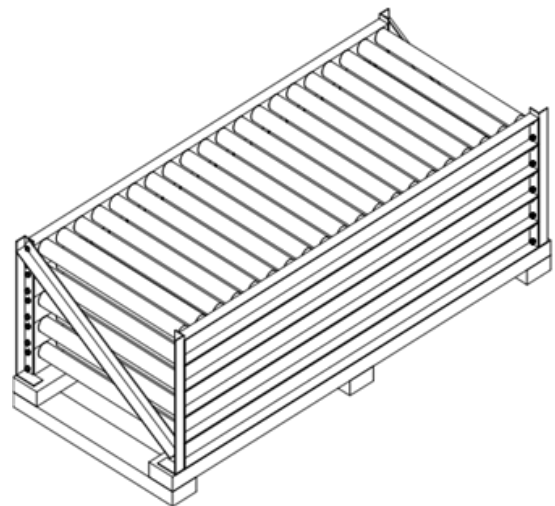

MULTIPLE SECTIONS

UNCRATING

1. Remove crating and packaging.
2. Check for boxes, accessories, bags, or components such as fasteners, manuals, guard rails, etc. that may be banded or fastened to the crating material.

Ensure fasteners, guards, and essential components are not discarded.

INSTALLATION

CHECKING SQUARENESS

Frame squareness can be checked by using a simple right angle square as shown or by measuring from the same points diagonally, corner to corner. See image below for reference.

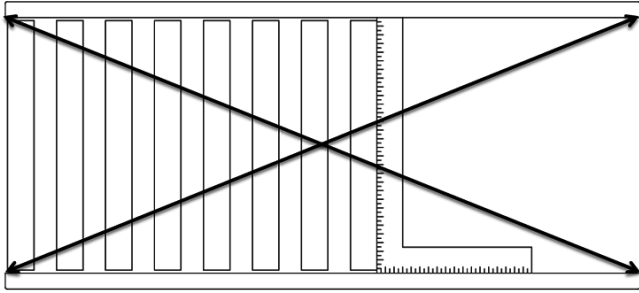

NOTE

Ensure frames are square or products will skew and tumble from the conveyor. Failure to square frames may also cause premature conveyor wear and failure.

SQUARING WITH TURNBUCKLES

Bolt-together conveyor frames may be brought square by means of attaching turnbuckles to each corner and turning them down appropriately until square.

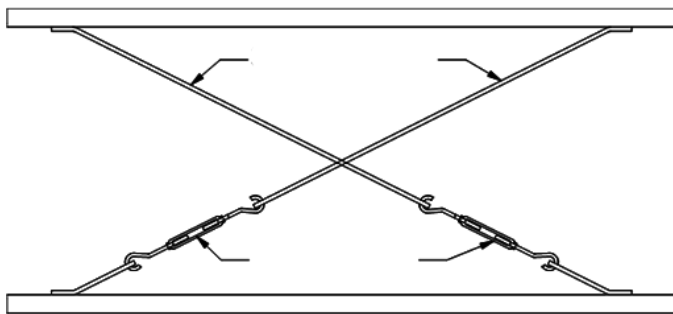

NOTE

Only trained professionals should attempt to square a conveyor.

COUPLING

Couple the sections using bolts provided per the drawing below.

NOTE

For ease of installation, mount legs on each section of conveyor prior to coupling.

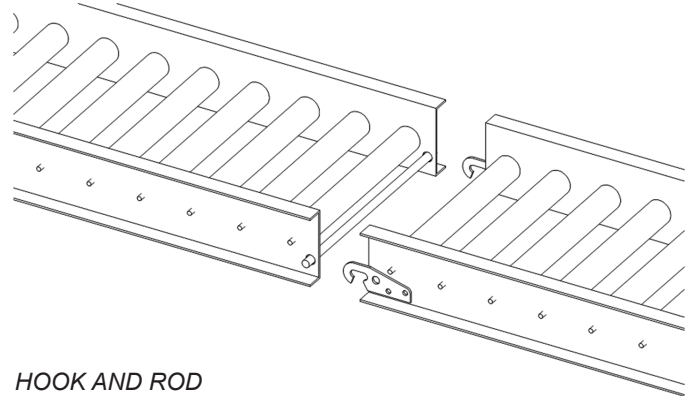

HOOK AND ROD

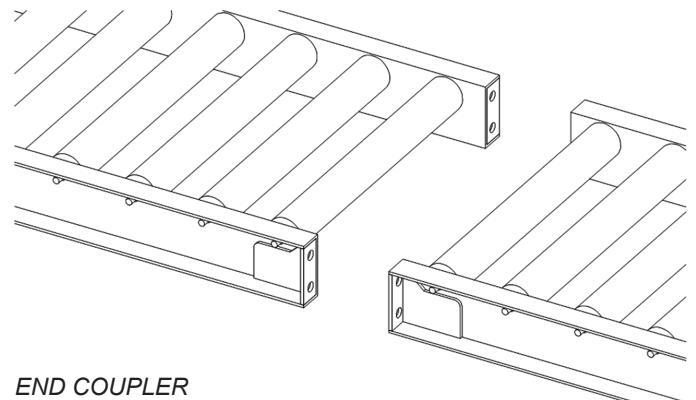

END COUPLER

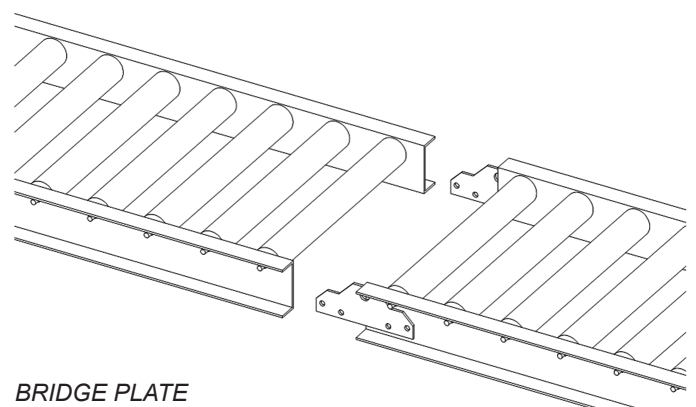

BRIDGE PLATE

INSTALLATION

PERMANENT INSTALLATION OF LEGS



Secure leg supports to the floor utilizing the lag holes in the adjustable leg boot.

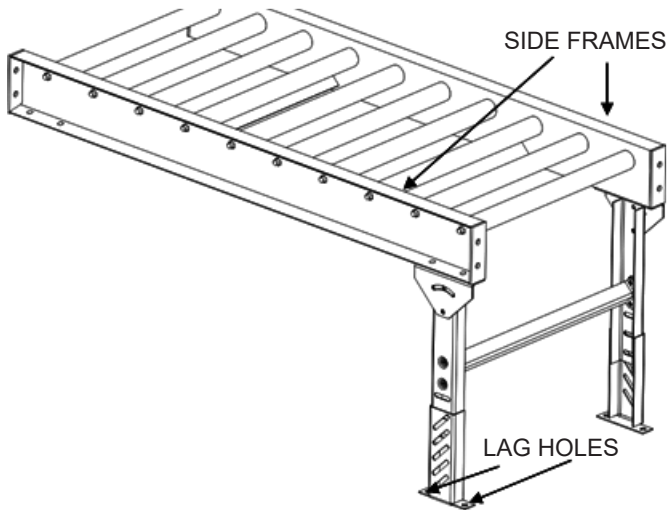

NOTE

Ensure conveyor is level by placing a level on the conveyor side frames. If the conveyor is not level, adjust the legs as shown below.

LEG ADJUSTMENT: BOLT-TOGETHER LEGS

1. Any conveyor or adjacent equipment electrical power must be turned off and locked out/tagged out following your company's machine specific procedures.
2. Remove all load from the conveyor.
3. Position conveyor in the location to be installed.
4. Support conveyor section with a jack, hoist, or forklift.
5. Carefully loosen the fasteners within the slots.
6. Lift or lower conveyor until it is at the desired height.
7. Ensure the conveyor is completely level.
8. Tighten fasteners using torque appropriate for each fastener's size and grade.

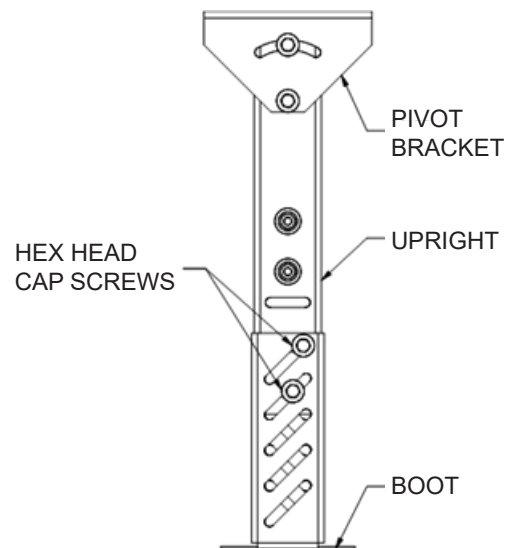

NOTE

Only qualified installation professionals should level and install a conveyor.

INSTALLATION

WELDED LEG ADJUSTMENTS

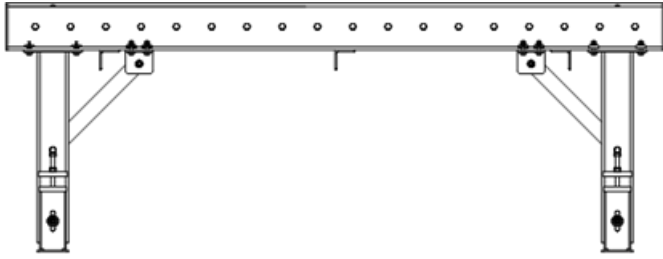

WELDED LEG ADJUSTMENT: JACK-BOLT

1. Any conveyor or adjacent equipment electrical power must be turned off and locked out/tagged out following your company's machine specific procedures.
2. Remove all load from the conveyor.
3. Position conveyor in the location to be installed.
4. Support conveyor section with a jack, hoist, or forklift.
5. Carefully loosen the retaining bolt.
6. Carefully loosen the jam nut holding the jack-bolt in position on the jack-bolt plate.
7. Adjust the boot position by turning the jack-bolt.
8. Ensure the conveyor is completely level.
9. Tighten the jam nut securely against the jack-bolt plate using torque appropriate for each fastener's size and grade.
10. Tighten the retaining bolt using torque appropriate for each fastener's size and grade.

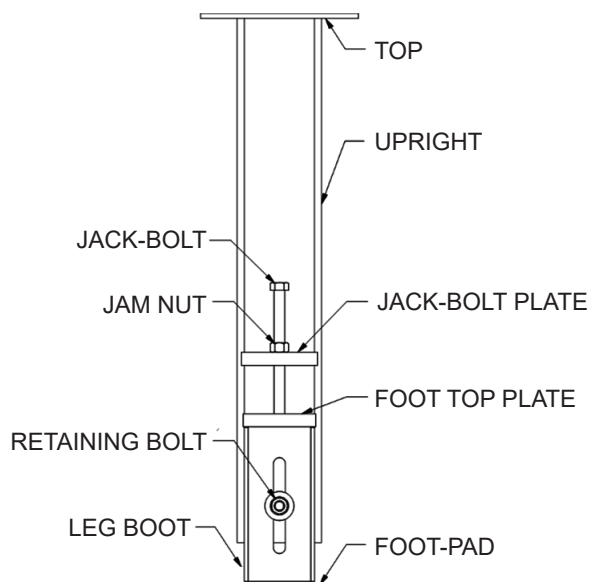

WELDED LEG ADJUSTMENT: NON-JACK-BOLT

1. Any conveyor or adjacent equipment electrical power must be turned off and locked out/tagged out following your company's machine specific procedures.
2. Remove all load from the conveyor.
3. Position conveyor in the location to be installed.
4. Support conveyor section with a jack, hoist, or forklift.
5. Carefully loosen the retaining bolt.
6. Lift or lower conveyor until it is at the desired height.
7. Ensure the conveyor is completely level.
8. Tighten fasteners using torque appropriate for each fastener's size and grade.
9. Secure the leg boot to the upright by either of the methods listed below:
 - A) Weld the boot into place.
 - B) Drill through boot and upright and bolt the boot securely into place.

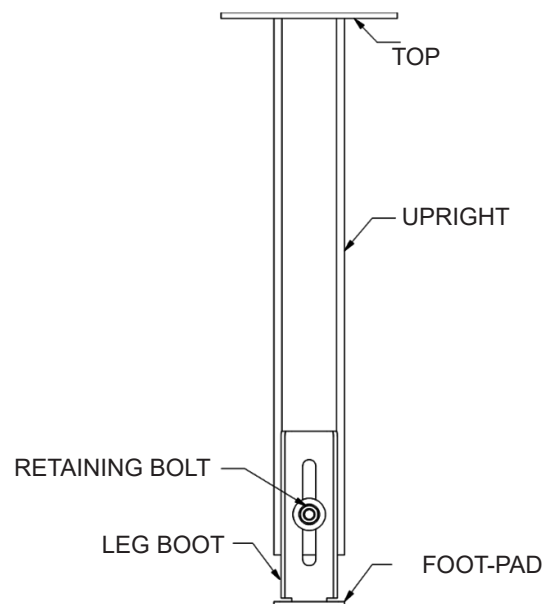

INSTALLATION

INSTALLING KNEE BRACES (BOLT-ON)

1. After leg supports are set in place, attach the brace bracket.
2. Attach knee brace angle to the leg support and brace bracket. Knee brace angle may need to be cut, drilled, and trimmed for proper fit and to eliminate interference with adjacent equipment.

NOTE

Knee braces are recommended when the conveyor height exceeds 36" and/or when additional stability is needed.

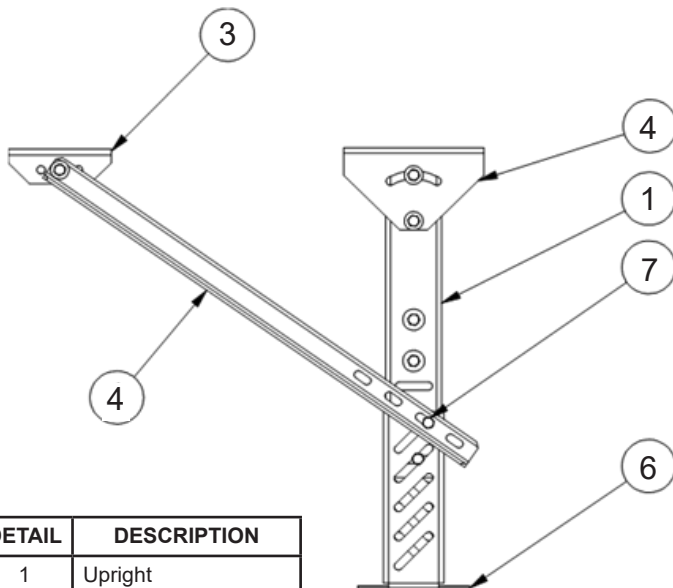

DETAIL	DESCRIPTION
1	Upright
2	Spreader
3	Brace Bracket
4	Knee Brace Angle
5	Pivot Bracket
6	Foot
7	Hex Head Cap Screw

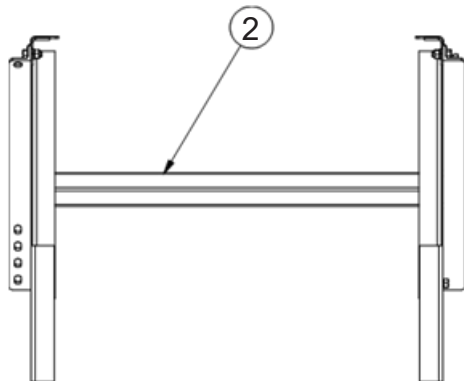

INSTALLING KNEE BRACES (WELDED)

1. After leg supports are set in place, attach the brace bracket.
2. Attach knee brace angle to the leg support and brace bracket.

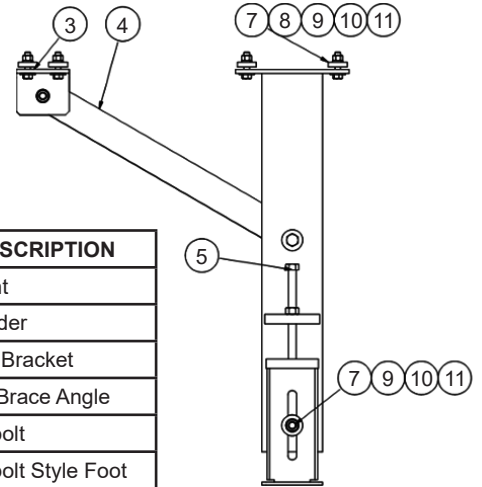

DETAIL	DESCRIPTION
1	Upright
2	Spreader
3	Brace Bracket
4	Knee Brace Angle
5	Jack-bolt
6	Jack-bolt Style Foot
7	Hex Head Cap Screw
8	Bevel Washer
9	Hex Nut
10	Flat Washer
11	Lock Washer

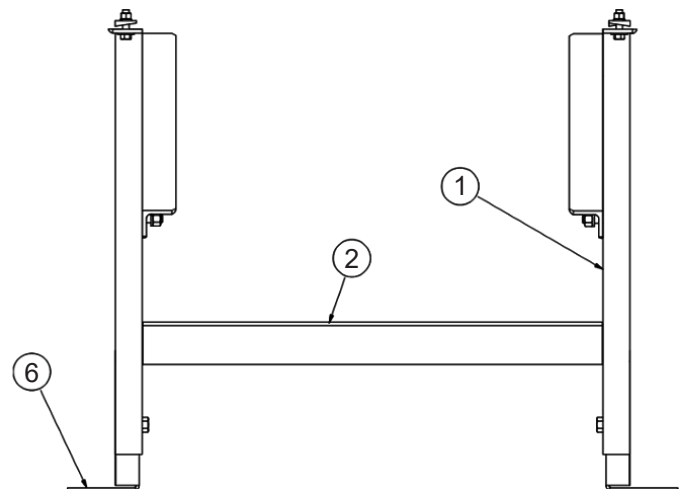

NOTE

Knee braces are recommended when the conveyor height exceeds 36" and/or when additional stability is needed.

INSTALLATION

INSTALLING CASTERS

Once in position, casters should be locked until conveyor needs to be moved again.

NOTE

Leg supports with casters follow similar installation instructions as standard leg supports and knee braces.

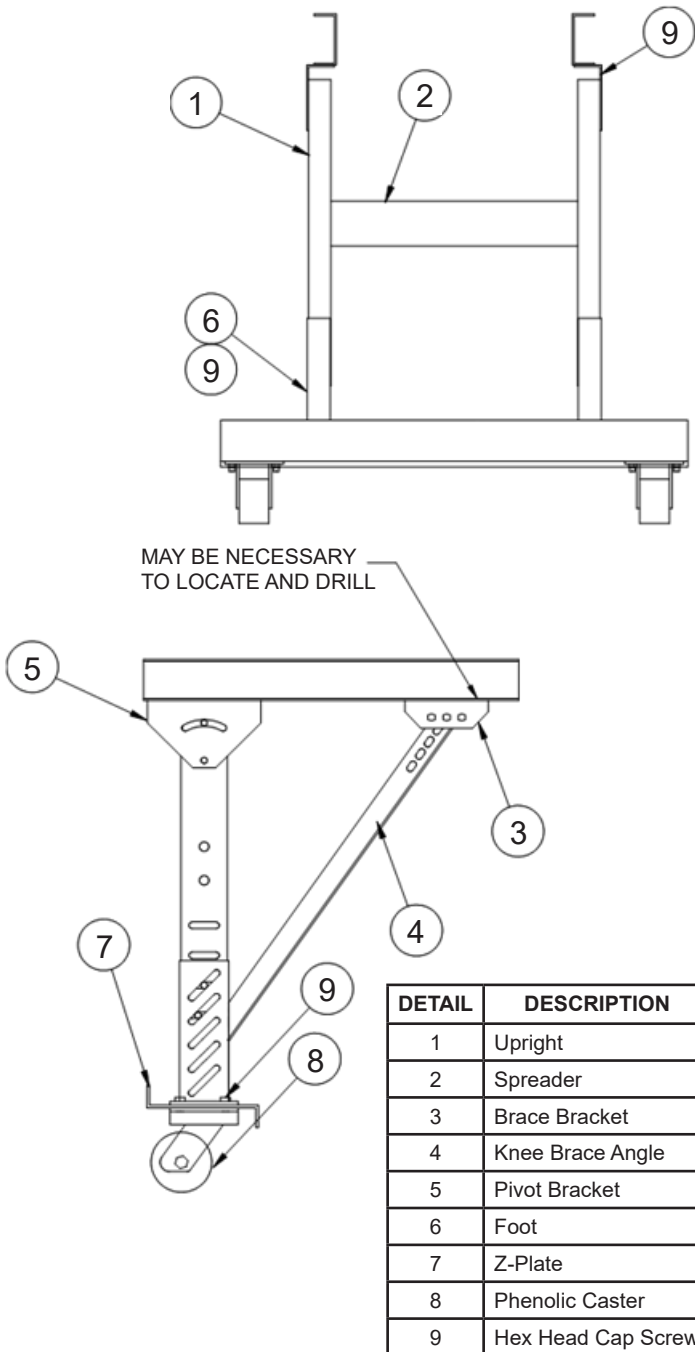

INSTALLING CEILING HANGERS

When using conveyors in an overhead scenario, mount hangers at section joints.

NOTE

When installing ceiling hangers, refer to local building codes to ensure that materials comply. Only experienced material handling installers should attempt to install conveyors.

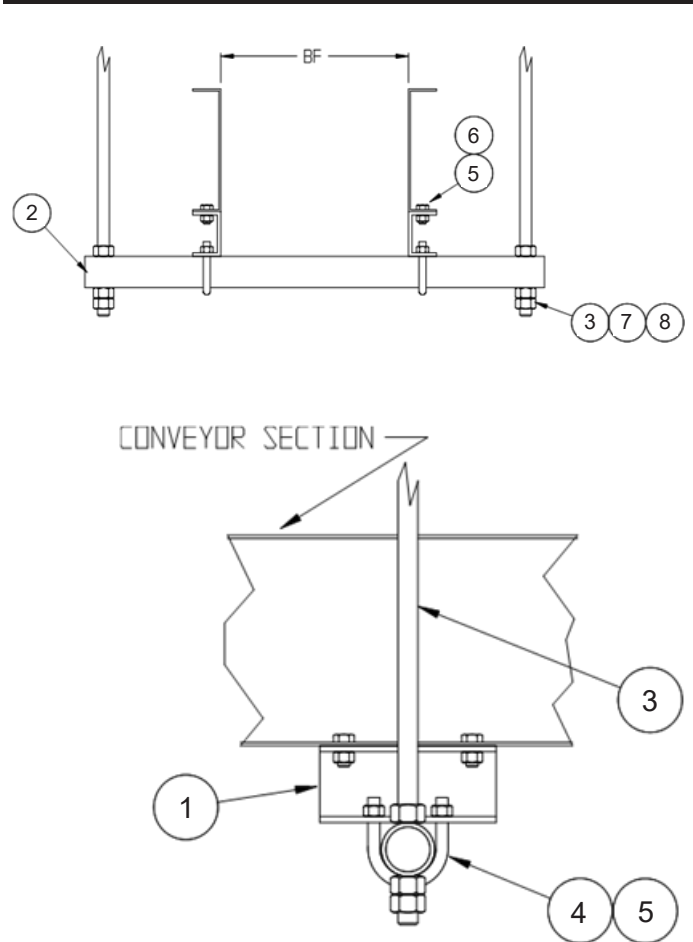

INSTALLATION

INSTALLING MULTI-TIER SUPPORTS

1. Remove the upper spreader (detail 2 in image below) from support.
2. Lower the conveyor section onto the lower spreader (detail 2) and attach using supplied fasteners.
3. Check for appropriate elevation and attach the knee bracket assembly (detail 3, 4, 6, 7, 8).
4. For upper conveyor assembly, replace upper spreader and repeat steps 2 and 3.
5. Make sure all multi-tier supports are in line and square prior to conveyor start-up.

NOTE

Make sure conveyor is stable prior to multi-tier assembly. Use of a forklift or crane may be required to ensure safe handling. Only experienced installation professionals should install conveyor.

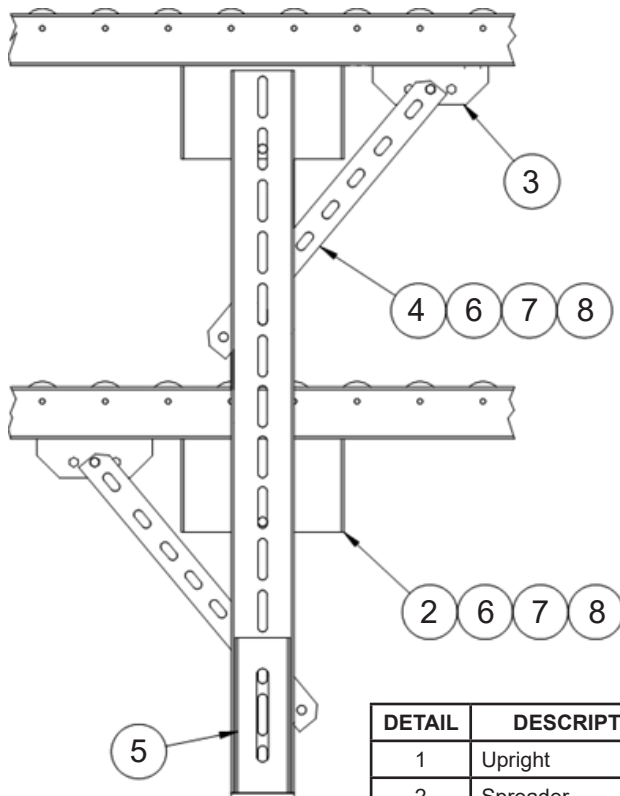

DETAIL	DESCRIPTION
1	Upright
2	Spreader
3	Brace Bracket
4	Knee Brace Angle
5	Foot Weldment
6	Whiz Nut
7	Hex Head Cap Screw
8	Flat Washer

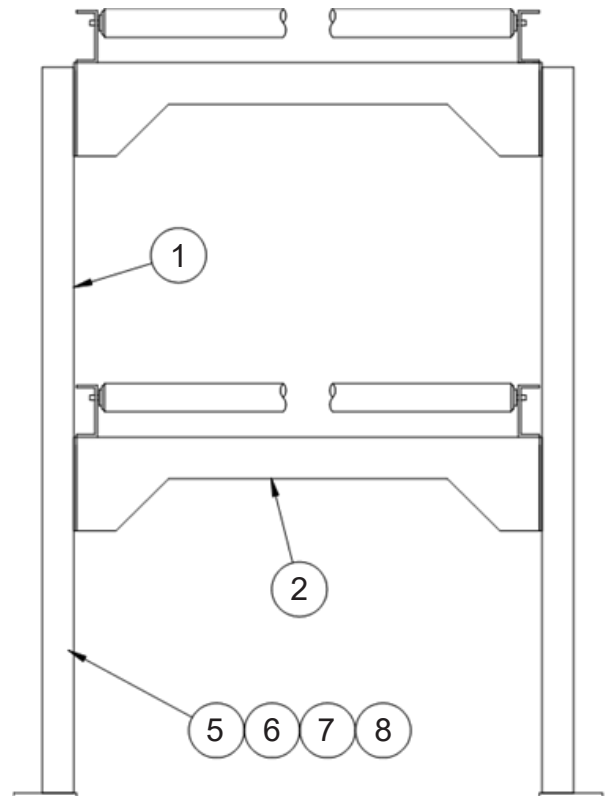

GENERAL PREVENTATIVE MAINTENANCE

Periodic maintenance intervals shown may vary with load, speed, hours of daily operation, ambient temperature, humidity, etc. Intervals can be established by fairly frequent maintenance at first; then lengthen the intervals as justified by observation of need based on history. The following is based on 5 days per week, 8 hours per day under normal conditions.



WARNING

- **Prohibit riding on conveyor by anyone.**
- **Think before making any adjustments. It may prevent an injury. Remember, all moving components are potentially dangerous.**
- **Protect yourself from unexpected starts when working on a stopped unit by locking the control panel or disconnect switch that supplies power to the unit and/or connected equipment.**
- **Lockout/Tagout procedures must be followed for every energy source of the conveyor.**

Follow general maintenance safety procedures and review safety material prior to performing maintenance on any equipment.

Regular inspections are recommended by the manufacturer to ensure proper operation of mechanical, electrical and safety systems.

MONTHLY MAINTENANCE

- Perform an auditory inspection to identify any unusual noise that may indicate a problem with the conveyor.
- Inspect conveyor for loose bolts.
- Inspect rollers to ensure they rotate freely.

QUARTERLY MAINTENANCE

- Perform an auditory inspection to identify any unusual noise that may indicate a problem with the conveyor.
- Inspect conveyor for loose bolts.
- Inspect rollers to ensure they rotate freely.

PARTS REPLACEMENT PROCEDURES



WARNING

Before starting any maintenance procedure, the **ELECTRICAL SERVICE MUST BE TURNED OFF AND LOCKED OUT.**



WARNING

Replace all safety devices and guarding prior to equipment start-up.

ROLLER REPLACEMENT

Regularly scheduled preventative maintenance will ensure maximum component life. In the event of excessive wear or damage to a roller, complete the following procedure.

1. One or both ends of the roller may be spring retained. Identify which end of roller is spring retained. Using a small diameter punch or similar tool, apply linear pressure to the shaft on the opposite end until the shaft clears the inside of the frame.

NOTE

Be careful to **NOT** apply side load pressure to the roller shaft.

2. Apply upward force on the roller body until the roller shaft lifts out of the frame completely. It is recommended to place a putty knife or similar flat surface tool between the shaft and the inside of the frame to protect the finish on the inside of the conveyor frame.
3. Place the new roller's shaft into the hole in the conveyor frame.
4. Press on spring-loaded idler shaft using putty knife and slide roller into place, so that shaft sets in the opening in the opposite conveyor frame.

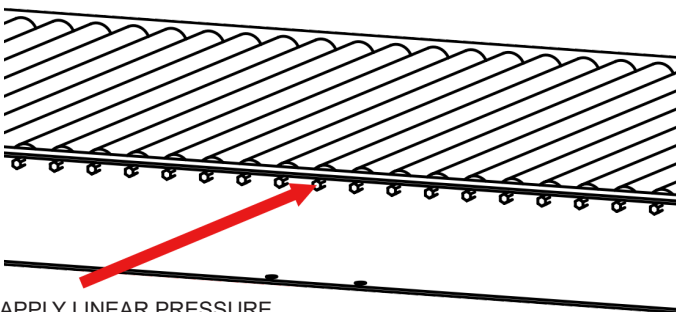

APPLY LINEAR PRESSURE

GENERAL TROUBLESHOOTING

The troubleshooting information contained on the following pages is general in nature and is intended to provide an efficient means of pinpointing a correct solution in a timely manner.

Equipment malfunctions or failures may occur at any time. Following a regularly scheduled preventative maintenance program can help to minimize conveyor down time. Scheduled maintenance can lessen the frequency of equipment repairs by keeping components running more efficiently and in a better working environment.

Prior to performing any maintenance or replacement procedures, **the electrical service must be turned off and locked out.**

The disassembly or repair of equipment under warranty may void such warranty (motor, reducer, cable reel, etc.). Check to be sure that the warranty has not expired or will not be voided prior to performing disassembly or repair.



WARNING

Replace all safety devices and guarding prior to equipment start up.

PROBLEM	CAUSE	SOLUTION
Product doesn't flow.	Insufficient decline.	Raise infeed height or lower discharge height.
	Rollers don't rotate freely.	Replace damaged rollers.
	Poor bottoms on product.	Improve conveyability of product.
Product skews as it travels down the line.	Rollers are not square in frame.	Inspect and square frame according to instructions in INSTALLATION section.

WARRANTY STATEMENT

The Seller warrants that the Equipment will be free of defects in workmanship and material (if properly installed, operated and maintained) for a period of one year or 2080 hours of use, whichever is sooner, from date of shipment to Customer, subject to the limitations hereunder set forth. If within the one year warranty period, the Seller receives from the Customer written notice of any alleged defects in the Equipment and if the Equipment is not found to be in conformity with this warranty (the Customer having provided the Seller a reasonable opportunity to perform any appropriate tests thereon) Seller will, at its option, either repair the Equipment or supply a replacement therefore.

The Seller under either option shall have the right to require Customer to deliver the Equipment to Seller's designated service center and the Customer shall pay all charges for in-bound and out-bound transportation and for services of any kind, diagnostic or otherwise, excepting only the direct and actual costs of repairing or replacing the Equipment. If after reasonable effort the Seller cannot correct said deficiencies, the Seller will make an equitable price adjustment based on actual performance, provided that such adjustment shall under no circumstances exceed the purchase price. The Seller further warrants that the parts, and components supplied by the Seller and forming a part of the Equipment will be free from defects in material and workmanship for a period of one year or 2080 hours of use, whichever is sooner, from date of shipment to the Customer. The Seller's liability shall be solely limited to the supplying of replacement parts and materials.

For a copy our full warranty included in our Terms and Conditions of Sale, contact ConveyX Solutions, LLC.

RETURN AUTHORIZATION PROCEDURES

If the component in question is included in the replacement parts package, the following procedure will apply:

- Identify the part number from the manual
- If part is indicated as wear part
 - Replace the damaged or defective part from parts inventory
 - Order additional parts as required
- If the part is indicated as a warranty part
 - Replace the damaged or defective part from parts inventory
 - Contact ConveyX Solutions, LLC for a Return Merchandise Authorization (RMA) number
 - Have conveyor serial number available when contacting CXL.
 - Send the part to the following address

ConveyX Solutions, LLC.
2380 US 23 South
Docks C, D, E
Alpena, MI 49707
 - Include the conveyor serial number and RMA number on the packaging and the packing slip
 - CXL will inspect the part and make a warranty determination
 - If the part is under warranty, CXL will...
 - Ship a replacement to Customer to replenish parts stock
 - Issue a credit for the freight

If the component in question is not included in the replacement parts package, the following procedure will apply:

- Identify the part number from the manual
- Contact CXL for an initial review to establish if part is covered under warranty and to provide a quote if needed.
 - Have conveyor serial number available when contacting CXL
- Issue a purchase order for a replacement part
- CXL will issue a Return Merchandise Authorization (RMA) number for the part to be returned.
- Send the part to the following address

ConveyX Solutions, LLC.
2380 US 23 South
Docks C, D, E
Alpena, MI 49707
- Include the conveyor serial number and RMA number on the packaging and the packing slip
- CXL will inspect the part and make a warranty determination
- If the part is under warranty, CXL will Issue a credit to Customer for the purchased part and associated freight charges

PARTS REFERENCE CHART AND DRAWINGS

GRAVITY ROLLER CONVEYOR WEAR/REPLACEMENT PARTS	
1	SIDE FRAME
2	GRAVITY ROLLER
3	BOLT-IN SPREADER
4	END COUPLER
5	HEX HEAD CAP SCREW
6	WHIZ NUT
7	OUTSIDE RAIL
8	INSIDE RAIL
9	LONG RAIL
10	SHORT RAIL
11	SHELF BRACKET
12	ROLLER SUPPORT
13	SHELF SUPPORT BRACKET
14	FLAT WASHER
15	HEX NUT

***PARTS LISTED ARE GENERIC AS SPECIFIC PART NUMBERS AND SIZES VARY BASED ON CONVEYOR**

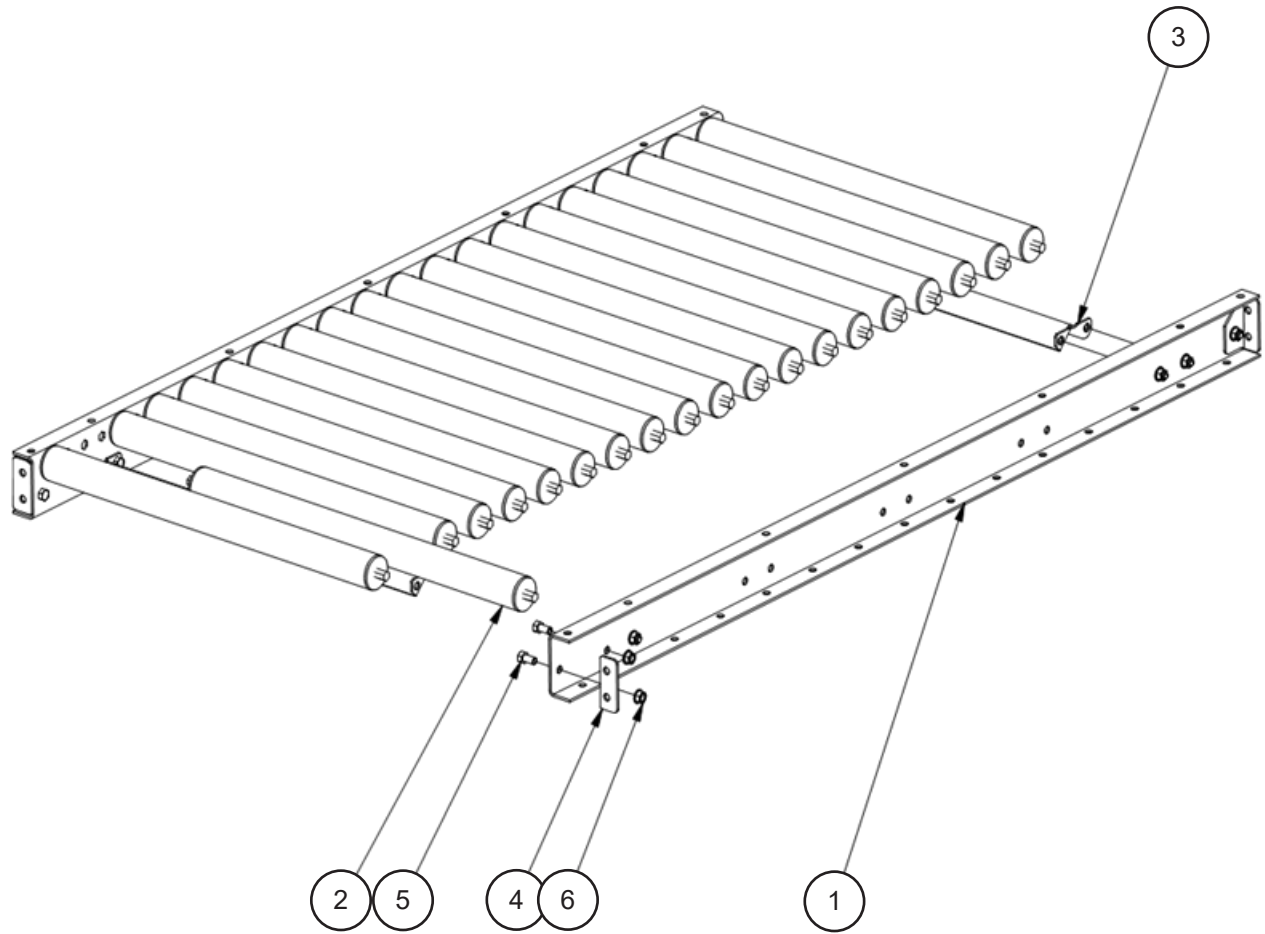

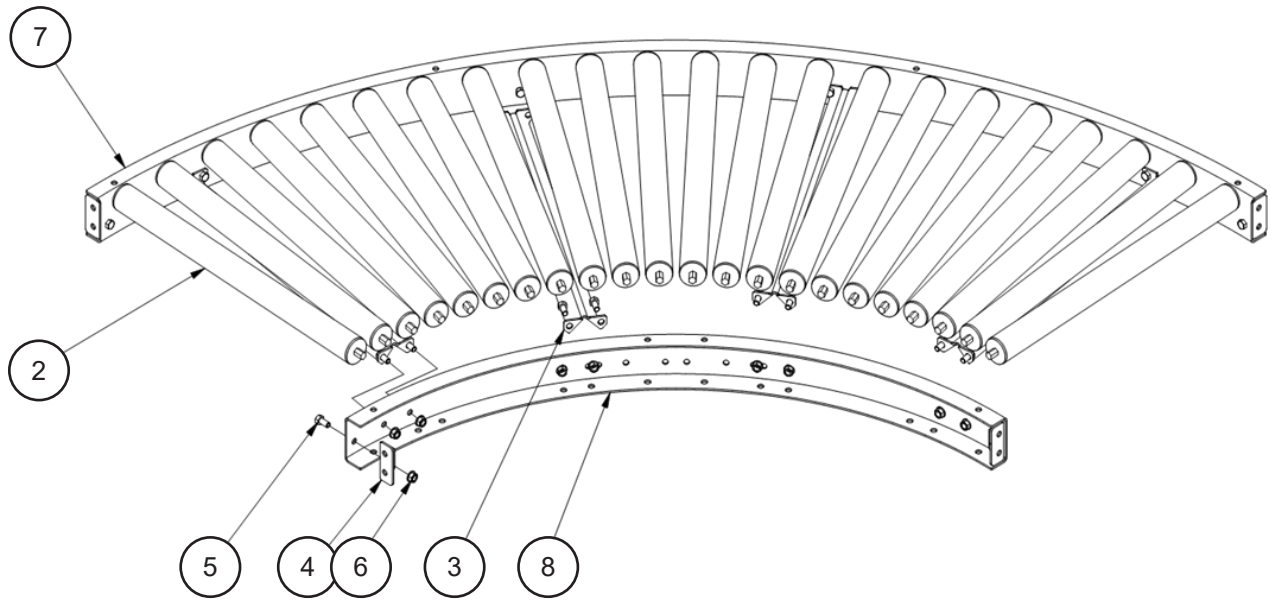

GRAVITY ROLLER CONVEYOR STRAIGHT SPUR

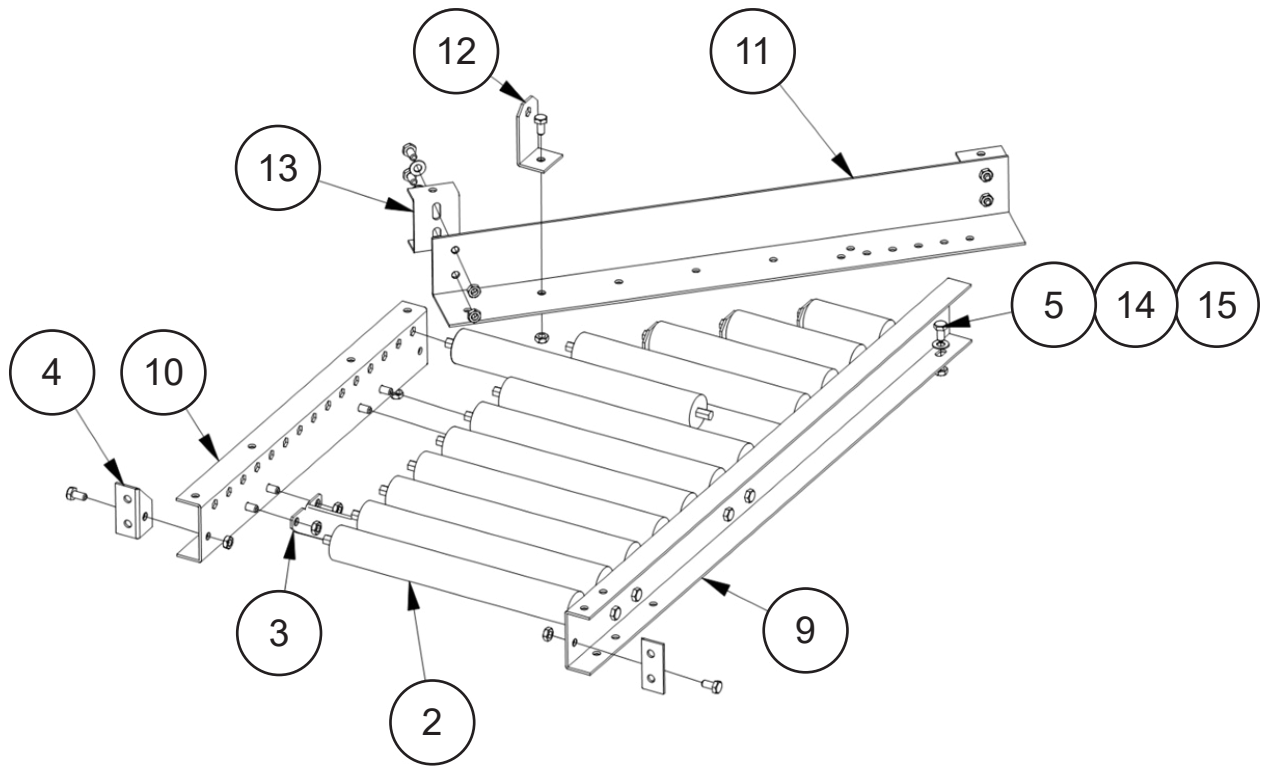

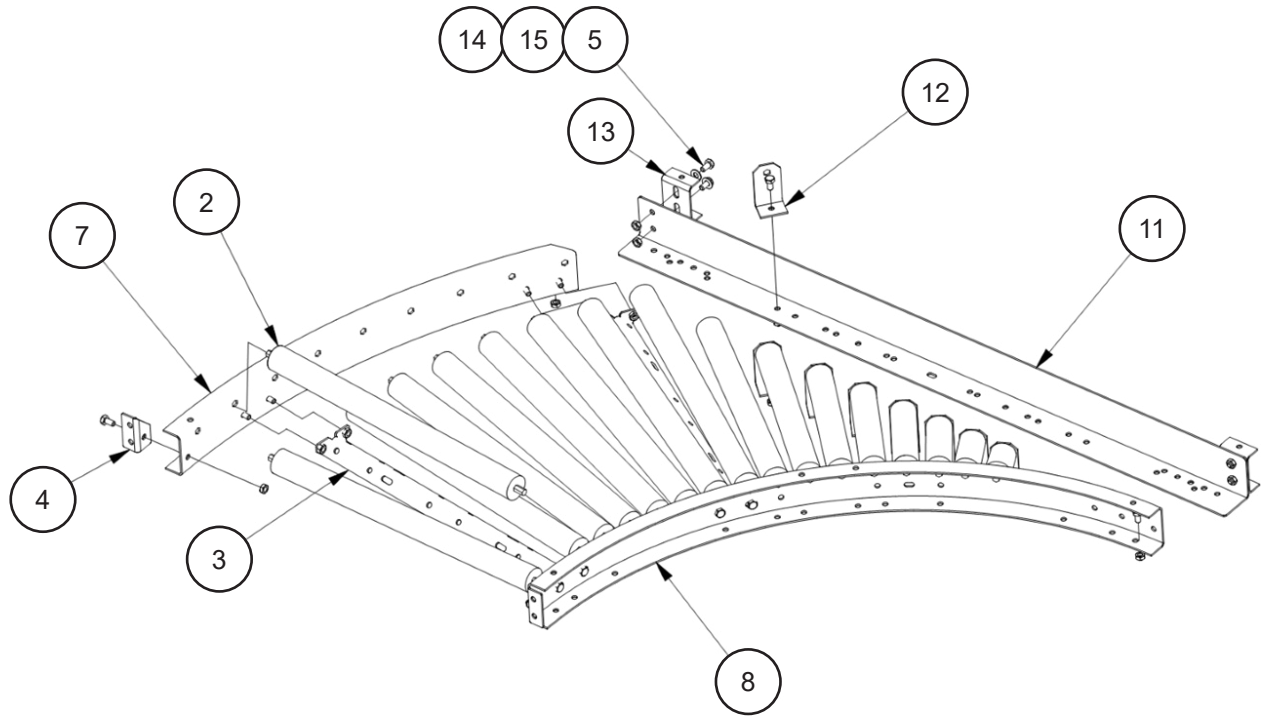



ConveyX Solutions, LLC strives to be the leading dock door conveyor solutions manufacturer in North America. Our load and unload material handling equipment is designed for unit handling applications delivering operational improvements and energy efficiency.

We build to our customers' specifications to enhance their processes with quality equipment and components. We specialize in rapid product development to exceed lead time and volume requirements.